



CPUT
Cape Peninsula
University of Technology
creating futures

ELM370S: Electrical Machines 3

Comprehensive Course Blueprint & Project Specifications

NQF Level 7 | 28 Credits | 280 Notional Hours

Department of Electrical,
Electronics, and Computer Engineering

Year: 2026

The Foundation: Building 280 Hours of Expertise

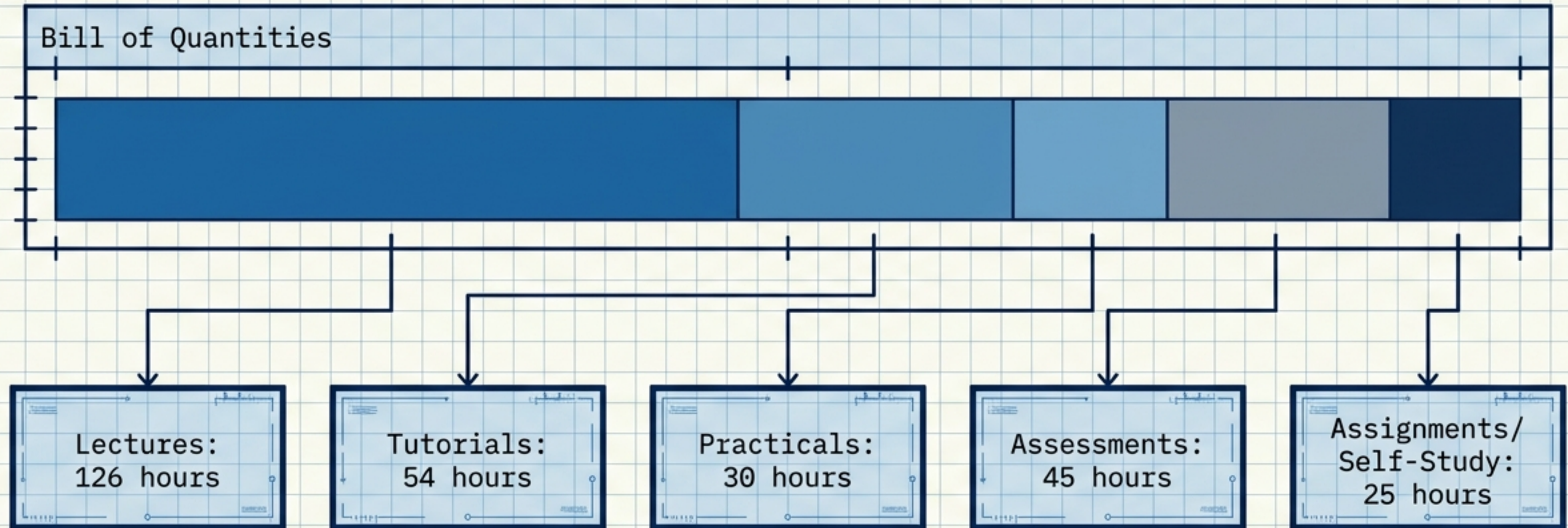

A minimum of 5 hours per week of self-study is required to maintain this trajectory.

The 2026 Syllabus Roadmap

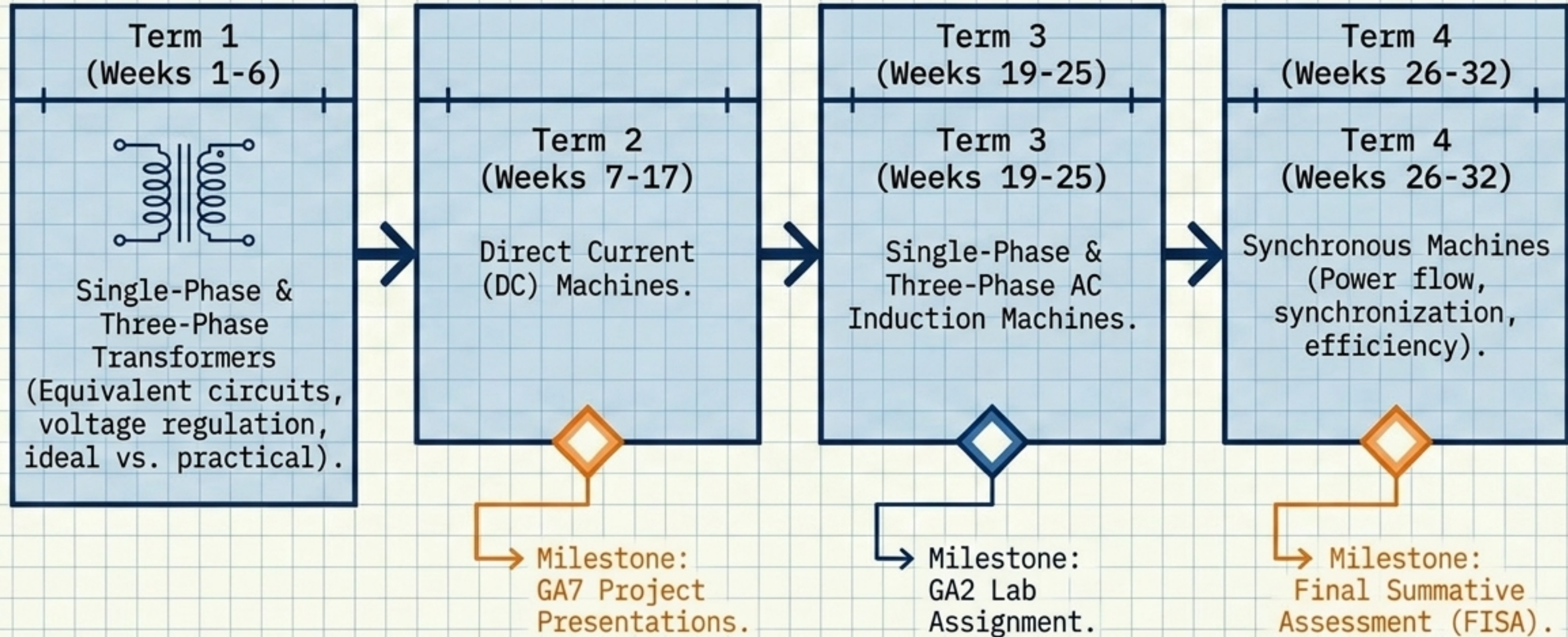

Assessment Specifications & Critical Subminimums

Total Mark Formula

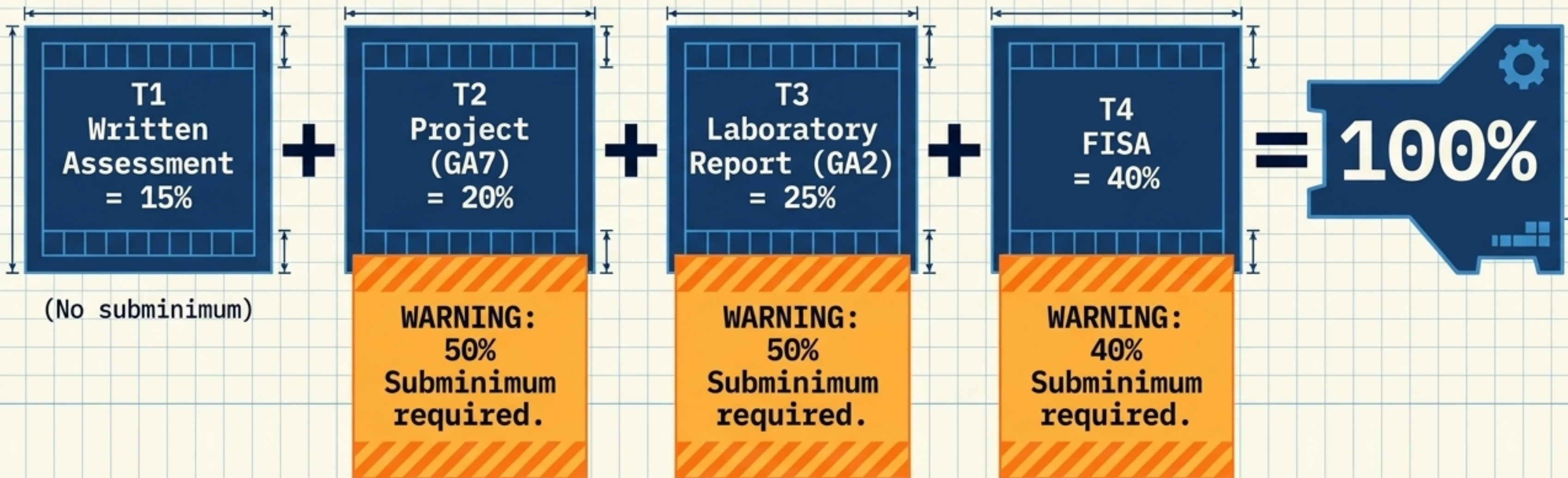

Crucial Note: Failing to meet any subminimum results in failing the entire course, regardless of your total mark. Exit-level project-based subjects allow NO reassessments after the final.

Professional Standards & Rules of Engagement



Attendance

80% Minimum Threshold.
Missing this disqualifies you from reassessments.
Inactivity (<20%) results in deregistration.



Plagiarism

>15% Similarity is grounds for disciplinary action.
A zero mark applies to intentional copying.



AI Usage

Generative AI (ChatGPT, etc.) requires an official declaration form. Fabricated references or undeclared AI usage constitutes academic misconduct.



Submission

Deadlines are absolute.
Zero marks are awarded for late submissions.
Engineers deliver on time.

The Prototype: Gully Plug Rainwater Harvesting System

Your major capstone project requires designing and building a functional, scaled prototype of a rainwater harvesting and management system.

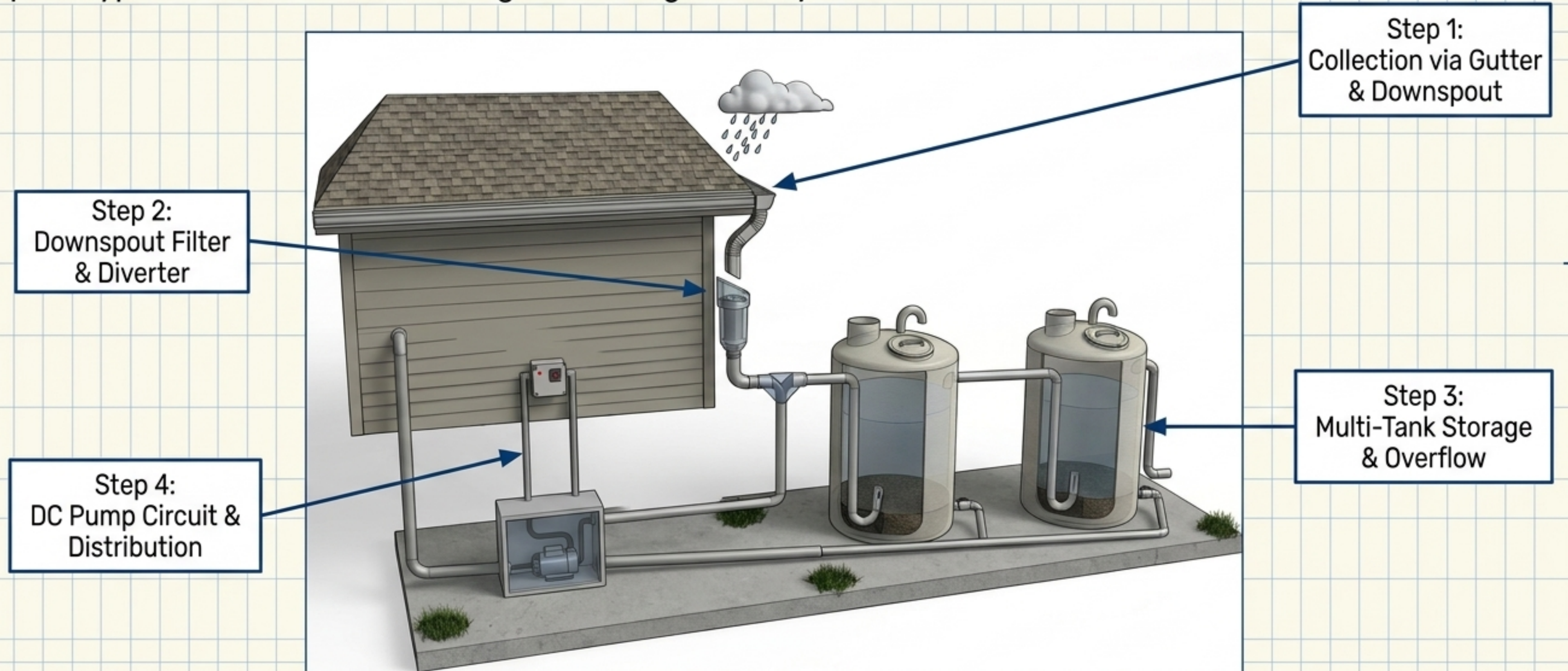

Mandatory Core Specifications: System Power

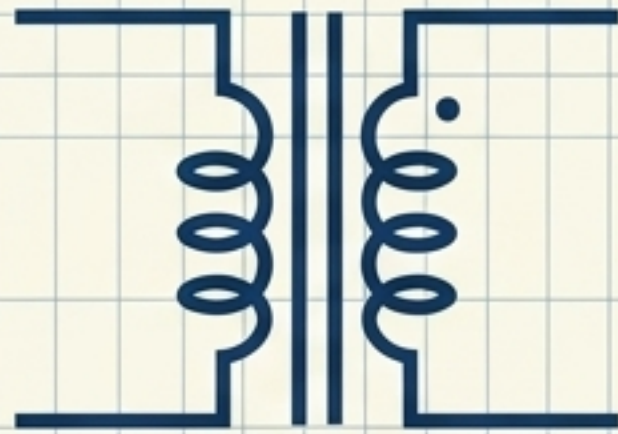

Rule 1: Mandatory Step-Down ⚠️

The **220V to 12V** step-down transformer is a **MANDATORY** requirement. It must appear in your circuit diagram, calculations, and report.

✓ Rule 2: Safety Boundaries ✓

Branch A: **9V–12V DC**: For DC motors, pumps, solenoid valves, and relay coils.

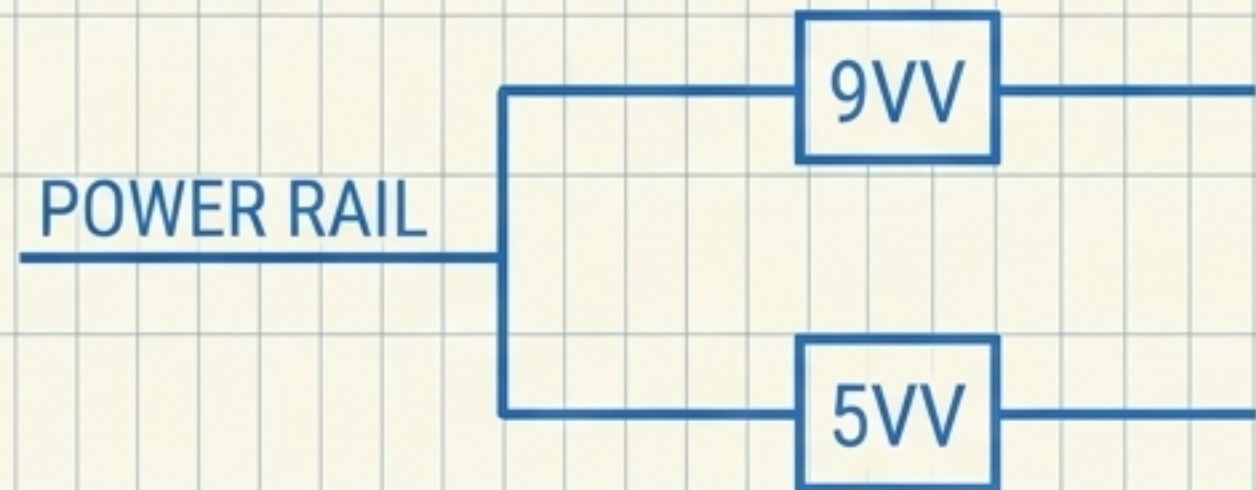

Branch B: **5V DC**: For ESP32 microcontrollers, sensors, and logic boards.

Note: No high-voltage or mains-level wiring is present in the prototype beyond the transformer.

Project Pathways: Choose Your Architecture

Option A (Recommended): IoT-Enabled System

- ✓ **Brain:** 2x ESP32 Microcontrollers
- ✓ **Control:** Fully automated (WiFi/Blynk app, LCD status)
- ✓ **Sensors:** Rain, ultrasonic levels, flow rate
- ✓ **Estimated Cost:** R1,728 – R3,339

Option B (Basic/Manual): Manual PWM System

- 📄 **Brain:** PWM Generator Module
- 📄 **Control:** Manual switches and potentiometer knob
- 📄 **Sensors:** Visual checking only
- 📄 **Estimated Cost:** R1,458 – R2,901

Option A Schematic: The IoT Automation Layer

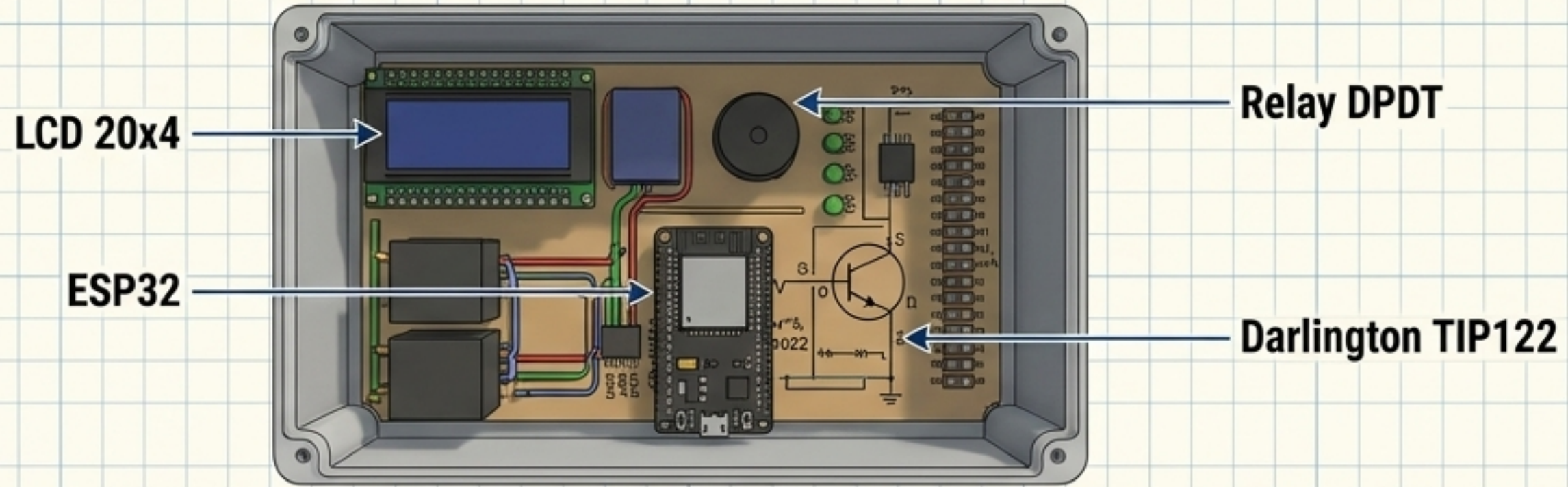

ESP32 Master/Slave:
Handles 3.3V logic
and WiFi dashboard.

LCD 20x4 I2C:
Local status display.

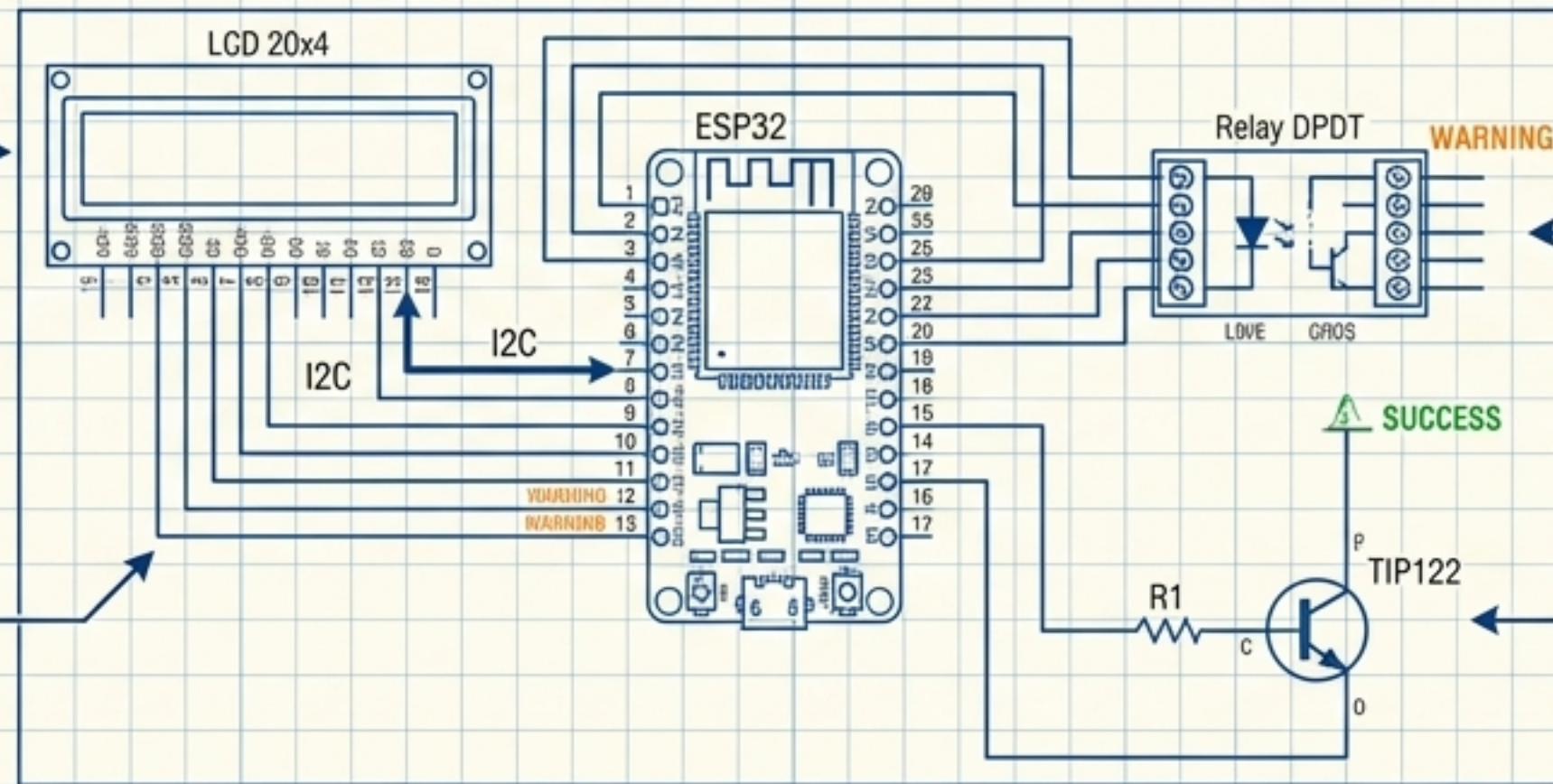

Relay DPDT:
Optocoupler isolated
pump switching.

Darlington TIP122:
Motor power amplification.

Option B Schematic: Manual Control Layer

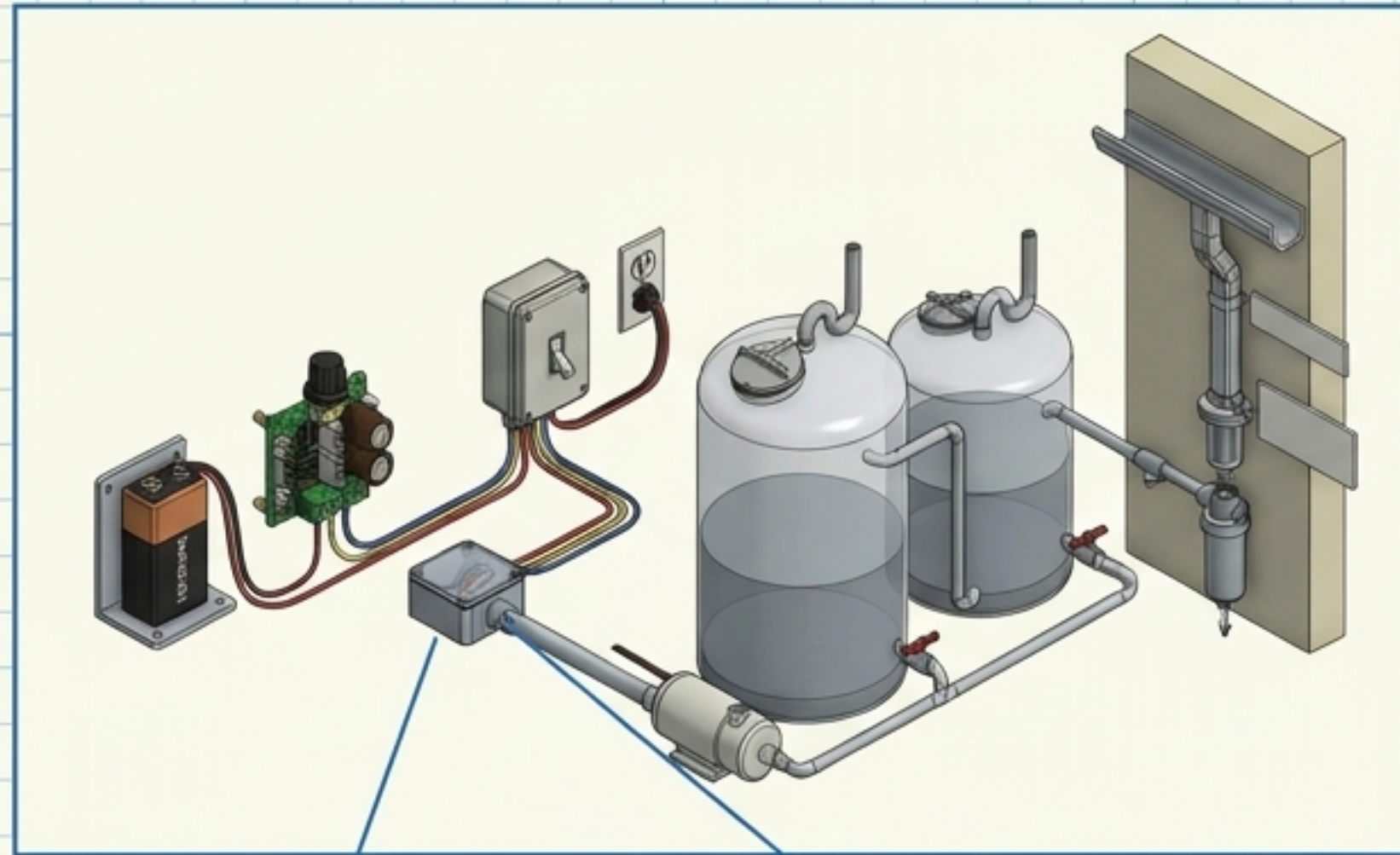

2 **9V Battery Source:**
Dedicated power for the pump circuit.

3 **Power Outlet Switch:**
Physical manual override for step 4 distribution.

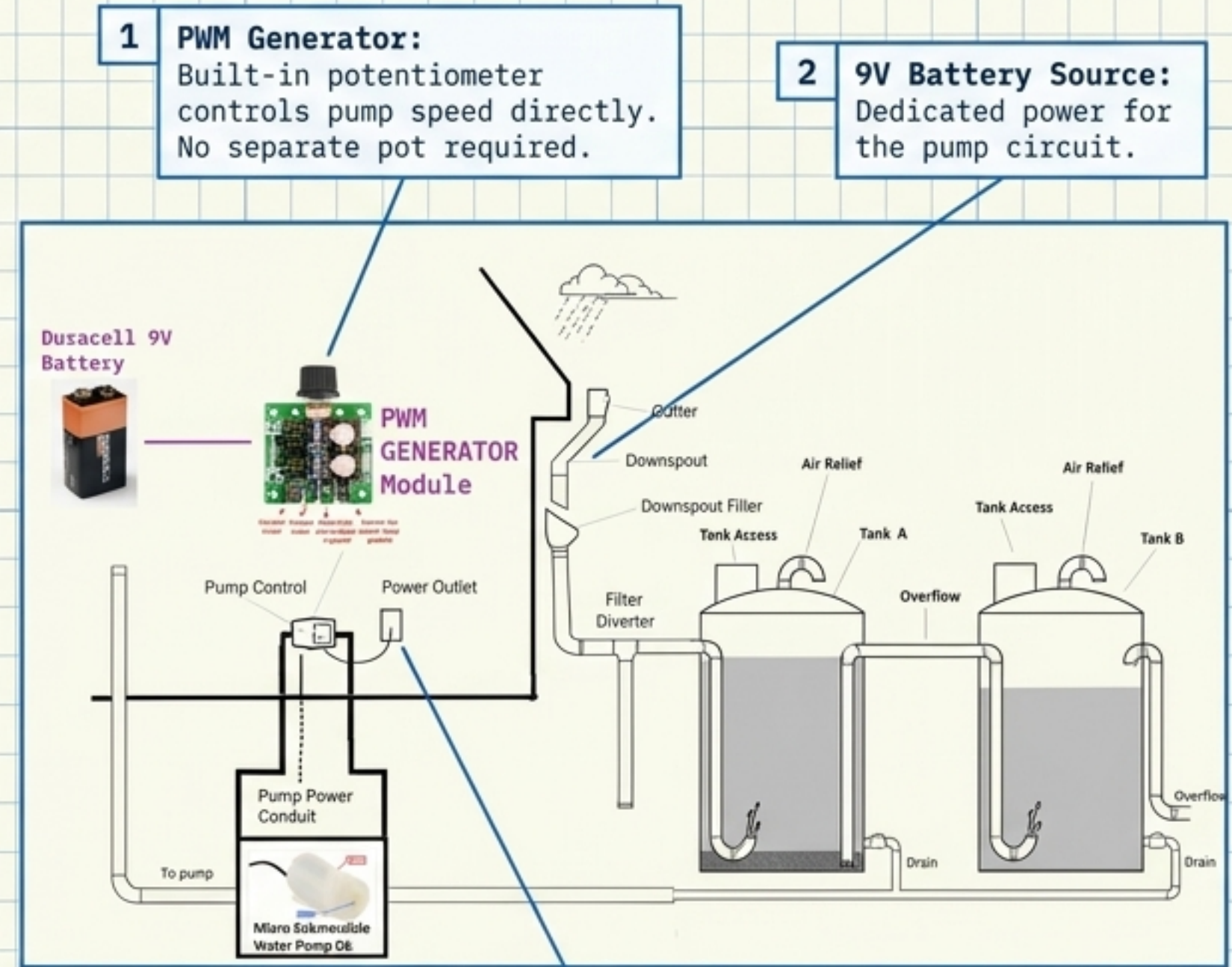

Mechanical Specifications: The Plumbing Architecture

Filter Diverter (Choose 1):

First-flush,
Downpipe collector,
or Filter Valve.

Storage:

3x 5L-10L HDPE
plastic containers
with Threaded PVC
Ball Valves.

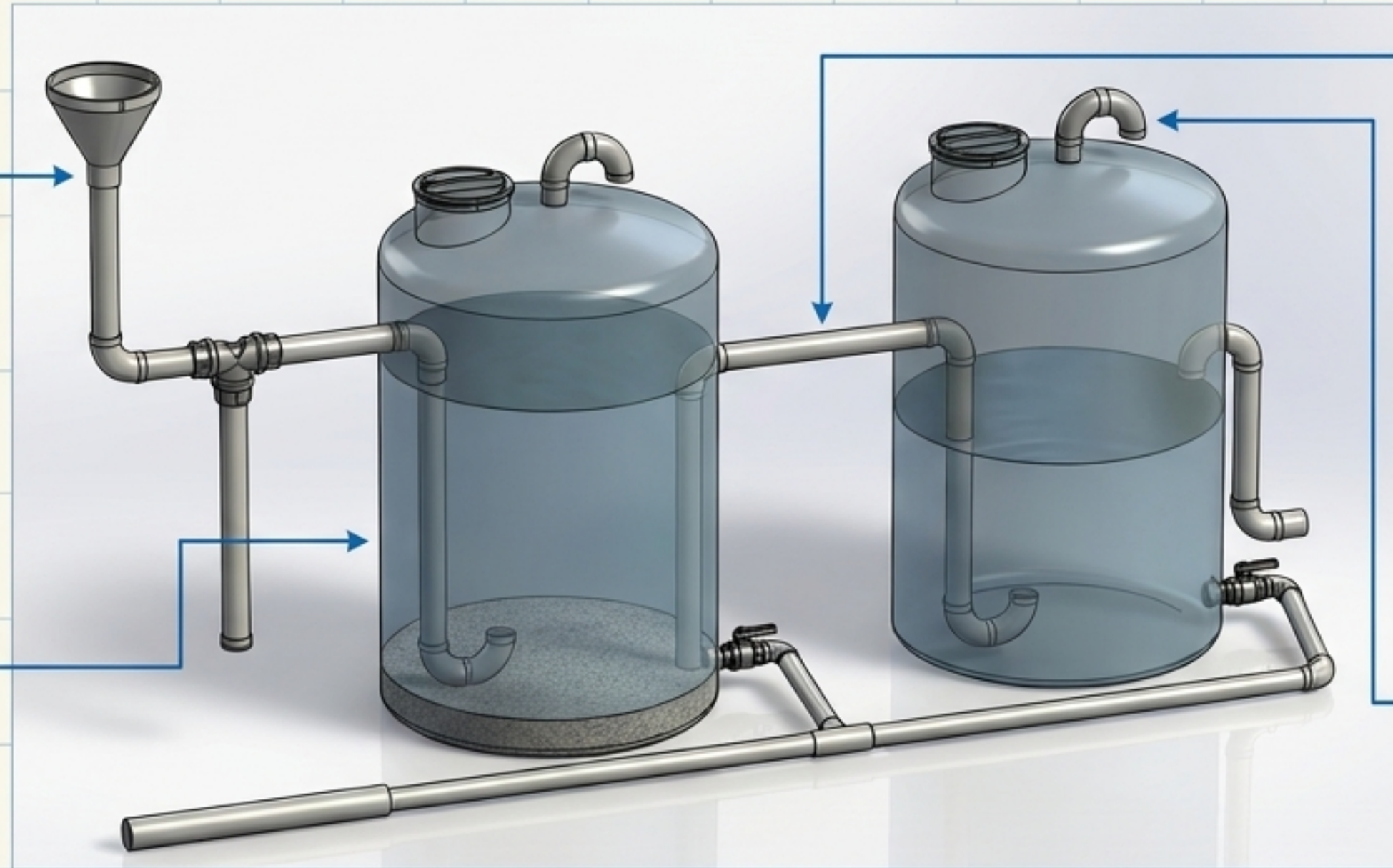

Piping:

20mm grey PVC
pipe connected
via T-Pieces and
90° Elbows.

Air Relief:

Vital to prevent
vacuum lock
during pump
draw.

Note: All PVC joints must be permanently bonded and sealed with clear waterproof silicone.

GA7 Assessment: Renewable Integration & Sustainability

Key Concept: To satisfy Graduate Attribute 7 (Impact of Engineering Activity), your project poster must detail real-world off-grid resilience.

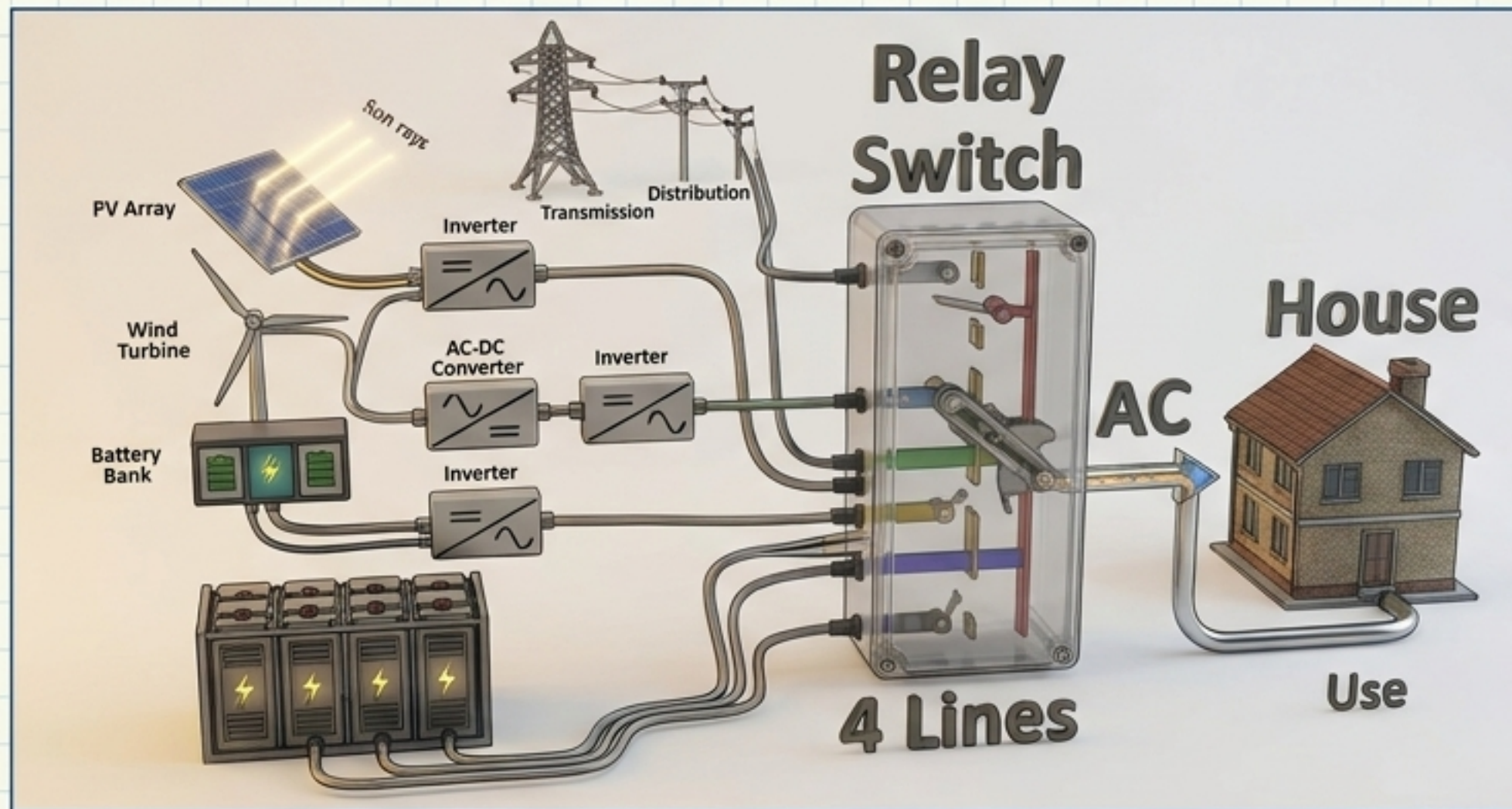

Theoretical Architecture:

- Solar PV Panel & PWM Charge Controller.
- Wind Turbine with AC-DC Rectifier.
- 12V Battery Bank & 4-Line Transfer Switch.

Note: These components are NOT required for the physical prototype. They represent full-scale engineering solutions for rural load-shedding resilience.

Bill of Materials & Local Procurement



Supplier Map

Microelectronics (Micro Robotics)

↳ ESP32s, Sensors,
Breadboards,
Buck converters.

Power & Circuitry (Communica CBD)





↳ 220V Transformers,
capacitors,
transistors, wire
rolls.

Hardware & Plumbing (Builders Warehouse / Leroy Merlin)

↳ IP65 Enclosures,
PVC pipes, Plywood
(Leroy Merlin offers
free cutting).

Engineering Note: Sourcing components locally is an explicitly assessable GA7 Outcome (Supporting local supply chains & SANS compliance).

Technical Report Standards & Final Verification

	Introduce Before Showing. Figures and Tables must be comprehensively introduced in the text before they appear. (No orphaned graphics).
	Precise Referencing. Do not use "the table below." Use direct references (e.g., "Table 1 illustrates...").
	Label Formatting. Figure titles go UNDER the graphic. Table titles go ABOVE the table.
	Mandatory Supervisor Review. Your project supervisor must review your final draft before formal submission. No exceptions.